

HabaCHAIN[®]

Miniature 60P (Straight)



Your Source For Habasit
Belting And Chain

www.StilesEnterprises.com • 1-800-325-4232

Description

Miniature 60P is a standard duty 3/4" (19.1 mm) pitch straight running only conveyor chain. Applications include packaging machines and applications that require a closed top plate design that eliminates pinch points.

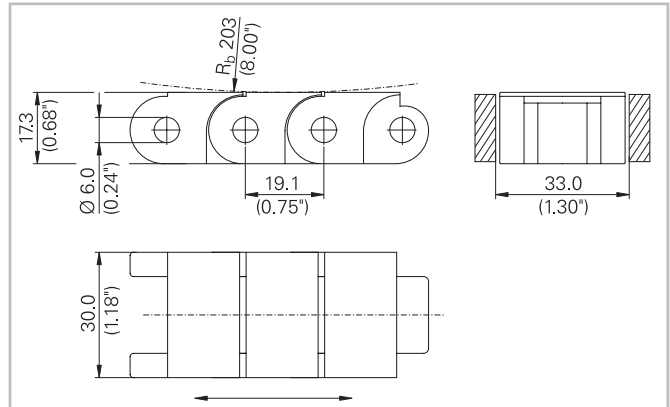

Chain Data

Habasit code	Width W		Weight		Nominal tensile strength F _N		Material
	mm	inch	kg/m	lb/ft	N	lbf	
C0060K0118DPAA+001	30.0	1.18	0.71	0.48	890	200	DP

Pin material: stainless steel

- Standard packaging: 3.048 m = 10ft
- The weight specification is indicative
- Other materials on request
- Driven by standard #60 roller chain sprockets

For further information and availability please contact your local Habasit partner.

Product liability, application considerations

If the proper selection and application of Habasit products are not recommended by an authorized Habasit sales specialist, the selection and application of Habasit products, including the related area of product safety, are the responsibility of the customer.

All indications / information are recommendations and believed to be reliable, but no representations, guarantees, or warranties of any kind are made as to their accuracy or suitability for particular applications. The data provided herein are based on laboratory work with small-scale test equipment, running at standard conditions, and do not necessarily match product performance in industrial use. New knowledge and experiences can lead to modifications and changes within a short time without prior notice.

BECAUSE CONDITIONS OF USE ARE OUTSIDE OF HABASIT'S AND ITS AFFILIATED COMPANIES CONTROL, WE CANNOT ASSUME ANY LIABILITY CONCERNING THE SUITABILITY AND PROCESS ABILITY OF THE PRODUCTS MENTIONED HEREIN. THIS ALSO APPLIES TO PROCESS RESULTS / OUTPUT / MANUFACTURING GOODS AS WELL AS TO POSSIBLE DEFECTS, DAMAGES, CONSEQUENTIAL DAMAGES, AND FURTHER-REACHING CONSEQUENCES.